



High quality of light for
spot and downlights

Fortimo LED SLM Gen3

PHILIPS

High quality of light for spot and downlights

For retail lighting applications it has long been recognized that high quality of white light is a key ingredient alongside an increasing awareness of the need for sustainable and highly efficient lighting solutions.

With the possibilities offered by the latest LED technology, lighting professionals are looking for the most compact and stylish luminaires, without any compromise on light quality and energy efficiency.

The third generation of Fortimo LED SLM proves it is now possible to have a high quality alternative for halogen, compact fluorescent and even compact HID fixtures, without any compromise on light quality and energy efficiency, but with the benefits of using LED technology.

The versatility of the Fortimo LED SLM can be truly appreciated when considering light sources for the two main applications in retail lighting, being spot lighting and general downlighting. Fortimo LED SLM Gen3 covers the requirements of both type of applications, by offering high energy efficiency combined with miniaturization, outstanding light quality and beam controllability. Both compact stylish downlight fixtures, as well as powerful spot lighting solutions will benefit from this third generation of Fortimo LED SLM.

What's new in Fortimo LED SLM Generation 3?

- Chip-On-Board (COB) technology, enabling amazing system efficiencies of over 100 lm/W
- Extended Tc up to 85°C possible
- New lower power driver combinations available
- Available up to 4500 lm
- Available in the colors 830, 930 and 840





Fortimo LED SLM for spot lighting

The third generation of the Fortimo LED SLM system is the ideal solution for spot lighting fixtures. It is specifically designed for the retail market and stands out in light quality and beam control, showcasing retail merchandise in bright and vivid light. This new generation is equipped with completely new Chip-On-Board (COB) LED technology.

- Powerful, compact and uniform light sources, enabling great beam control and small beam angles
- System performance of over 100 lm/W for high energy savings
- Long lifetime
- 2000 lm, 3000 lm and 4500 lm available in the same form factor

High quality white light

High quality white light is the essence of the third generation of the Fortimo LED SLM system, which has been specifically designed for creating the most attractive retail experience.

- The Fortimo LED SLM color points are identical to the benchmark in spot lighting, being the Philips MASTERColour CDM Elite lamp
- The highest brightness in the market due to a small Light Emitting Surface (LES), enabling the tightest beams
- The CRI 90 versions come with high R9 value, deeply enhancing red colours of merchandise

Smart System

The Fortimo LED SLM is designed to work together with the Xitanium LED drivers. This smart system approach includes the following essential features for spot lighting:

- Various compact LED drivers, including C-HID shapes, enabling miniaturized luminaires
- 12V output included for easy connection of active cooling systems
- Choice of different dimming systems such as Trailing Edge, Touch&Dim and DALI for scene setting and further energy savings
- Thermal derating system as an extra safety feature to secure the long lifetime and system specification

Easy design-in and approbation

Fortimo LED SLM systems have been designed with luminaire manufacturers needs in mind:

- High Tc-point of 75°C to reach optimal lifetime specifications
- Extended Tc of 85°C possible for further luminaire miniaturization
- ENEC, CB, REACH, RoHS certificated for fast and easy luminaire approbation
- Full set of complementary thermal and optical partner product available for quick luminaire design



Fortimo LED SLM for downlighting

The third generation of the Fortimo LED SLM system is the ideal solution for highly efficient and compact downlight luminaires. This new generation is equipped with completely new Chip-On-Board (COB) LED technology. This technology enables the creation of the most efficient LED system for downlight applications available from Philips.

- System performance of over 100 lm/W for high energy savings
- Long lifetime
- Higher lumen versions also very efficient

Smart System

The Fortimo LED SLM is designed to work together with the Xitanium LED drivers. This smart system approach includes the following essential features for downlighting:

- Independent driver with mains loop though, enabling easy installation with a remote driver
- DALI dimming for scene setting and further energy savings
- DC input enabled to ensure compatibility with central emergency system
- Thermal derating system as an extra safety feature to secure the long lifetime and system specification

Easy design-in and approbation

Fortimo LED SLM systems have been designed with luminaire manufacturers needs in mind:

- High Tc-point of 75°C to reach optimal lifetime specifications
- ENEC, CB, REACH, RoHS certified for fast and easy luminaire approbation
- Full set of complementary thermal and optical partner products available for quick luminaire design

Product specifications

Fortimo LED SLM Gen 3

Type	Light output (lm)	Module Power (W)	Module Efficacy (lm/W)	System Efficiency (lm/W)	Colour Temp. (K)	Colour Rendering (R _a)	Lumen maintenance @50 k hrs (%)	Colour consistency (SDCM)	Tc life (°C)
Fortimo LED SLM 2000 19W/830 L19 G3	2000	19.0	105	91	3000	>80	70	3	75
Fortimo LED SLM 2000 18W/840 L19 G3	2000	17.5	114	98	4000	>80	70	3	75
Fortimo LED SLM 2000 23W/930 L19 G3	2000	22.5	89	77	3000	>90	70	3	75
Fortimo LED SLM 3000 28W/830 L19 G3	3000	28.0	107	92	3000	>80	70	3	75
Fortimo LED SLM 3000 26W/840 L19 G3	3000	26.0	115	98	4000	>80	70	3	75
Fortimo LED SLM 3000 33W/930 L19 G3	3000	33.0	91	79	3000	>90	70	3	75
Fortimo LED SLM 4500 45W/830 L22 G3	4500	44.9	100	86	3000	>80	70	3	75
Fortimo LED SLM 4500 43W/840 L22 G3	4500	43.2	104	86	4000	>80	70	3	75
Fortimo LED SLM 4000 45W/930 L22 G3	4000	44.9	89	77	3000	>90	70	3	75

Fortimo LED SLM Gen3 Driver Portfolio

Module type	LED Driver	12NC Code	EOC Code
2000lm Gen3	Xitanium 25W LH 0.3-1A 36V 230V (NEW)	9290 008 33703	8718291 668084 00
2000lm Gen3 (2000/930 excluded)	Xitanium 25W 0.3-0.7A 36V TE/I 230V	9290 006 00303	8727900 907308 00
2000lm Gen3	Xitanium 25W 0.3-1A 36V TD/I 230V	9290 006 00403	8727900 914344 00
2000lm Gen3	Xitanium 25W 0.3-1A 36V TD/Is 230V	9290 004 85803	8727900 914351 00
2000/3000lm Gen3	Xitanium 36W LH 0.3-1A 48V 230V	9290 008 38903	8718291 666448 00
3000/4500*lm Gen3	Xitanium 50W/s 0.3-1A 62V 230V	9290 006 36403	8718291 137818 00
3000/4500*lm Gen3	Xitanium 50W SH 0.3-1A 62V 230V	9290 006 17403	8718291 137801 00
3000/4500*lm Gen3	Xitanium 50W 0.3-1A 62V 230V	9290 006 36303	8718291 137825 00
3000/4500*lm Gen3	Xitanium 50W 0.3-1A 62V TD/TE 230V	9290 006 61203	8718291 157120 00
3000/4500*lm Gen3	Xitanium 50W LH 0.3-1A 62V TD/TE/I 230V	9290 006 17103	8718291 119470 00
3000/4500*lm Gen3	Xitanium 50W SH 0.3-1A 62V TD/TE/I 230V	9290 006 17203	8718291 119487 00

*The Fortimo LED SLM 4000 45W/930 L22 G3 module is included in the 4500lm range

Dimensions (mm)

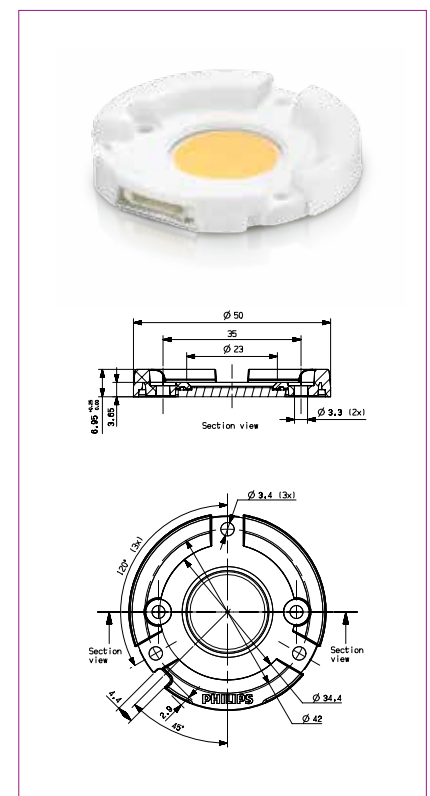

Ordering data

Fortimo LED SLM Gen3	Units per package	EOC codes	12NC codes
Fortimo LED SLM2000 19W/830 L19 G3	50	871829125372300	9290 008 17503
Fortimo LED SLM2000 18W/840 L19 G3	50	871829125374700	9290 008 17603
Fortimo LED SLM2000 23W/930 L19 G3	50	871829125376100	9290 008 17903
Fortimo LED SLM3000 28W/830 L19 G3	50	871829125378500	9290 008 18003
Fortimo LED SLM3000 26W/840 L19 G3	50	871829125380800	9290 008 18103
Fortimo LED SLM3000 33W/930 L19 G3	50	871829125382200	9290 008 18203
Fortimo LED SLM 4500 45W/830 L22 G3	50	871829169115000	9290 008 63103
Fortimo LED SLM 4500 43W/840 L22 G3	50	871829169117400	9290 008 63203
Fortimo LED SLM 4000 45W/930 L22 G3	50	871829169113600	9290 008 63003

Future Proof system

Together with the wide range of compatible Philips Xitanium LED drivers, the Fortimo LED SLM Gen3 system is future proof, easy to design in, has long lifetime and is backed up by the Philips five-year system guarantee. The SLM modules assure fixed lumen output, light distribution, and a standardized optical, mechanical, electrical and thermal interface. The module design is Zhaga compliant and is backwards compatible with previous SLM generation modules and drivers.



5 year
system
guarantee



For more information, please visit:
www.philips.com/fortimo



©2013 Koninklijke Philips N.V. (Royal Philips)
All rights reserved.

Document order number: 3222 635 66774